

WS 9S

不可剥离半导体屏蔽层剥离器

Warning! This tool is not protected against electrical shock! Always use OSHA/ANSI or other industry approved eye protection when using tools. This tool is not to be used for purposes other than intended. Read carefully and understand instructions before using this tool.

注意: 该工具特别设计用来对35KV以上电力电缆不可剥离半导体屏蔽层的剥离工作,工作电缆直径范围从12.7mm 到63.5mm,最大半导体层厚度可达2.54mm. 该工具也可用于可剥离半导体屏蔽层的剥离工作.

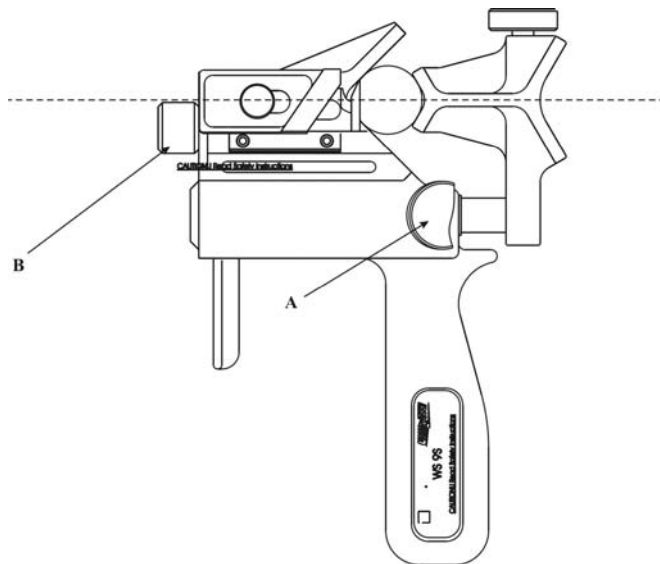

工具调节

1. 首先如何抓紧电缆,
张开工具夹口,用它把电缆抓紧,同时刀片离开工作电缆的末端.一手抓紧工具顶端,另一手锁紧**A**旋钮,使电缆被夹口牢牢抓紧.
2. 如何调节刀片深度
先注意电缆的末端,调节旋钮**B**使切割刀面在半导体层下,稍微深入绝缘层.稍加压力并旋转几圈,注意多少绝缘层被削除,后退进刀的深度直到合适的半导体被消除.(最初几毫米的绝缘层削除不会影响电缆的使用)

现在工具可以开始工作了

操作使用说明

工作前保证电缆截面平整.

1. 先将要切削工作的电缆拉直.
2. 按工具调节上的方法将电缆抓紧.
3. 围着电缆持续旋转工具.
4. 偶尔移出已削出的半导体层,使它不会缠绕在电缆上.

Ripley / Utility Tool Accessories

可更换切割刀片 CB 40X -- P/N 21715

备注:Ripley/ Utility Tool

WS 9S 是 WS 9A的最新替代工具

WARRANTY: The Ripley Company warrants that our line of tools are free of defect and fully operable at the time of shipment. The warranty is limited to the repair or replacement of any product which proves to be defective in material or workmanship, under normal use and service.



46 Nooks Hill Road
Cromwell, CT 06416
Phone: 800-528-8665
Int'l: (01) 860-635-2200
Fax: (01) 860-635-3631
e-mail: info@ripley-tools.com
Internet: www.ripley-tools.com



37667

AN 8.20.04